

Vorsprung

Smashpot

V2 BOTTOMLESS COIL SPRING SYSTEM

INSTALLATION MANUAL

FOX/RS/DVO/OHLINS



REVISION G
2026-01-29

Tools required:

NOTE: Do not proceed unless you have the following tools and supplies on hand.

- Torque Wrench (+adaptors to fit all sockets)
- 12mm Wrench
- 14mm Wrench
- 19mm deep socket
- Footnut socket
 - 12mm (Fox,RS,DVO)
 - 14mm (Ohlins)
- Chamferless Top-Cap socket
 - 28mm – All (except – see below)
 - 32mm – Fox 38, Fox 40
- Oil syringe and/or measuring cup
- Utility/Stanley Knife
- Heat Gun
- Small Flat Head Screwdriver
- Slickoleum Grease or equivalent
- 80 ml of 5wt fork oil (for spring side)
- Lint free towels/rag
- Caliper or ruler

**Damper side oil – please refer to manufacturers specifications for a lower leg service to determine if a different oil weight/viscosity is required in the lowers of the damper side.

ASSEMBLY

PART 1 – REMOVING THE STOCK AIR SPRING ASSEMBLY FROM YOUR FORK	4
PART 2 – CONFIGURING YOUR SMASHPOT TO YOUR TRAVEL & SPRING RATE	6
PART 3 – INSTALLING THE SMASHPOT ASSEMBLY INTO YOUR FORK	13

Also included:

SMASHPOT TUNING - HBO ADJUSTMENT	16
SERVICING YOUR FORK LOWERS & SMASHPOT	17
SERVICING YOUR SMASHPOT	17
CHANGING COIL SPRINGS	18

PART 1 – REMOVING THE STOCK AIR SPRING ASSEMBLY FROM YOUR FORK

1. See manufacturer's service instructions for disassembling the stock air spring and removing it completely from your fork. The Vorsprung Smashpot kit will replace the entire stock air spring assembly including foot stud and top cap and this must be removed first.

Refer to the relevant factory service instructions up until you have removed the air spring from the stanchion. Unless your fork requires additional servicing, the damper and seals will not need to be touched to install the Smashpot.

FOX: [Click here](#)

ROCKSHOX: [Click here](#)

DVO: [Click here](#)

OHLINS: [Click here](#)

MANITOU: [Click Here](#)

EXT: Contact EXT dealer for air spring removal tool.

Refer to the Factory service instructions for torque specifications, lubrication specifications and general disassembly/reassembly.

1. DVO FORKS ONLY:

When upper assembly is removed from casting (lowers), you may need to apply heat to stanchion plug on the AIR side, in order to break loctite for easier removal.

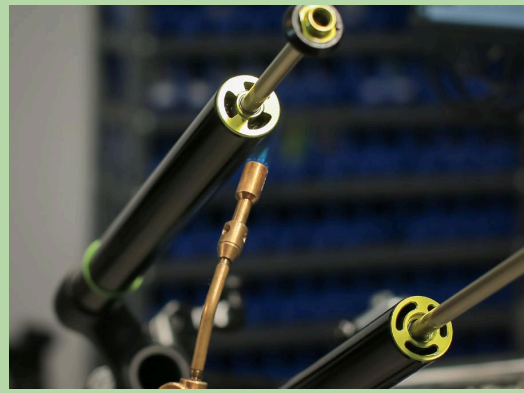

2. Remove footstud from OTT assembly. Remove the bottom out bumper from the OTT assembly.

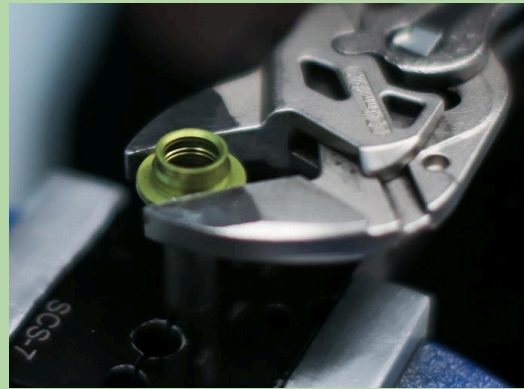

3. Stretch bottom out bumper over DAMPER side footstud, and onto the damper side shaft (in the same way that it was originally installed on the air side shaft). Ensure correct orientation – recess of bumper should seat around the footstud.



1. OHLINS FORKS ONLY:

Forks with a thread in the bottom of the springside stanchion may have an end cap threaded into it. This will need to be removed using a pin spanner. Ohlins offer a specific tool for this task, (part number 18867-01) however if you are using any other pin spanner be aware that while you can get the job done it is easy to slip and marr the end cap – be careful!

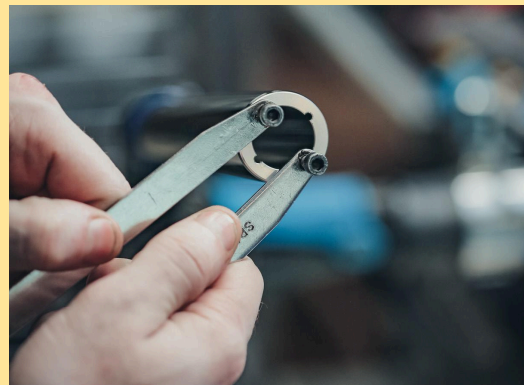

PART 2 – CONFIGURING YOUR SMASHPOT TO YOUR TRAVEL & SPRING RATE



- Smashpot Coil spring, Heat Shrink and Spring Isolators
- Smashpot Inner Tube Assembly
- Smashpot Outer Tube Assembly
- Smashpot Top Cap Kit – includes extenders and secondary spring if applicable
- Smashpot Decal (not pictured)

Your kit will consist of a number of items as per the above parts list. Depending on the travel of your fork you will have to configure the top out and main spring spacers accordingly.

In some cases the travel of your fork may be increased, however, it is your responsibility to check with the fork manufacturer to ensure this is permissible. Bushing overlap and damper length may restrict this and improperly installed products can fail, causing the rider to lose control resulting in **SERIOUS INJURY OR DEATH**. Check the maximum allowable travel of your fork with the fork manufacturer prior to increasing travel above your factory-set travel.

DRAWINGS

PARTS LIST		
ITEM	QTY	DESCRIPTION
1	1	INNER TUBE ASSEMBLY
2	AS REQ'D	TOP-OUT SPACERS (10/20mm SEE CHART FOR STACK REQ'D)
3	1	COIL SPRING ASSEMBLY (SPRING + ISOLATORS + HEAT SHRINK)
4	AS REQ'D	MAIN SPRING SPACERS (10/20mm SEE CHART FOR STACK REQ'D)
5	1	OUTER TUBE ASSEMBLY
6	1	TOPCAP (+20mm ADAPTOR AS REQ'D)

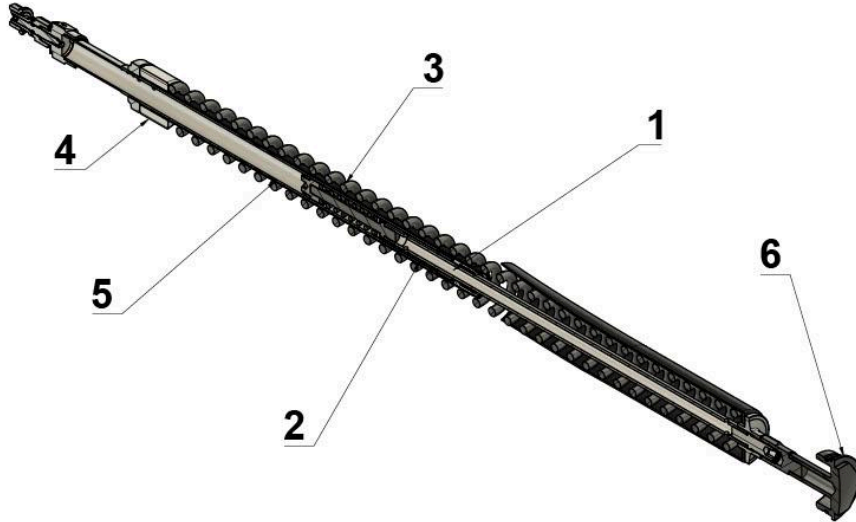

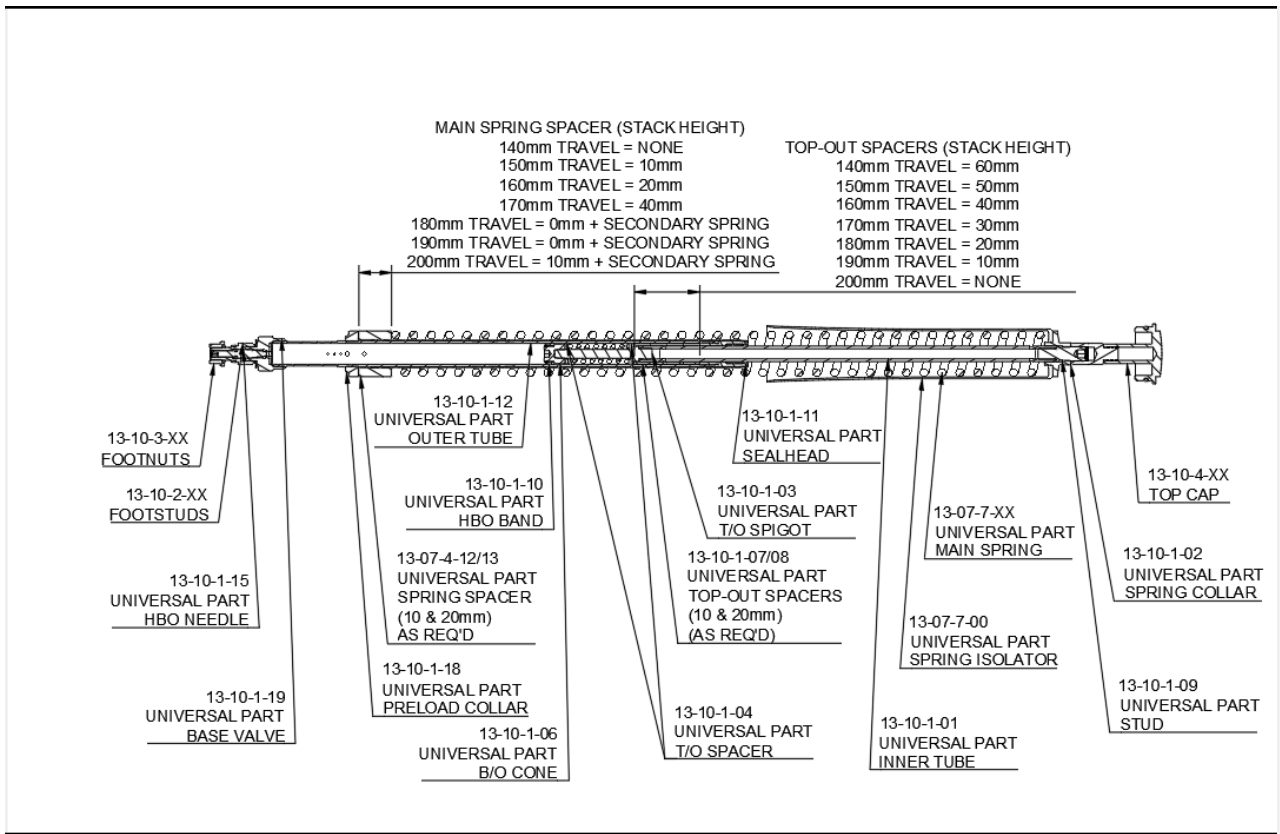

1. Remove SPRING COLLAR from the INNER TUBE ASSEMBLY in order to remove the SEALHEAD and access the TOP OUT SPRING SPACERS.



2. Install a stack height of TOP OUT SPRING SPACERS as required to suit your fork travel. TOP OUT SPRING SPACERS must sit on the INNER TUBE between TOP OUT SPRING ASSEMBLY and SEALHEAD. See table across for travel configurations. For example: a 180mm travel fork requires 20mm of TOP OUT SPRING SPACERS so install 1x 20mm spacer.

TOP OUT SPRING SPACERS	
Fork Travel (mm)	Spacer Stack Height (mm)
140	60
150	50
160	40
170	30
180	20
190*	10
200*	0

3. Re-install the SEAL HEAD onto the INNER TUBE ASSEMBLY and insert the INNER TUBE ASSEMBLY into the OUTER TUBE ASSEMBLY.

You might need to gently squeeze the spacers to get them past the threads. This is normal.



4. Using a 19mm deep socket on the BASE VALVE and 14mm wrench on the SEALHEAD torque to 75in.lbs (8.5Nm) without loctite.

NOTE: If you do not have a 19mm socket you can also use your specific footstud (socket sizes listed on page 2) to torque the SEALHEAD. The torque will be transmitted through the whole assembly



5. Position and install the included length of HEAT SHRINK just above the threads on the OUTER TUBE extending over the end of the SEAL HEAD using a heat gun.

****Make sure you do not cover the holes or threads with Heat Shrink**



6. Push INNER TUBE into the OUTER TUBE assembly as far as possible.

Using a sharp knife or scissors, trim back the Heat Shrink to be in line with the end of the Seal Head. (Try not to score the shaft with the knife but note that scratches are not critical – it is not a sealing surface.)



7. **Heat shrink is NOT used on the spring with 35mm SINGLECROWN forks (Lyrik, Yari etc).**

For all other forks including 35mm Boxxer: Slide the Heat Shrink provided on to the COIL SPRING, approximately 90–100mm from the top end of the spring.

Use a heat gun to heat the Heat Shrink until it fits snugly over the COIL SPRING. Once shrunk, trim any excess from the ends of the Heat Shrink that protrudes inside the inner diameter of the COIL SPRING.

Note: with 35mm Boxxer, the spring orientation will be set up such that the heat shrink is 100mm from the bottom end of the spring instead of 100mm from the top.

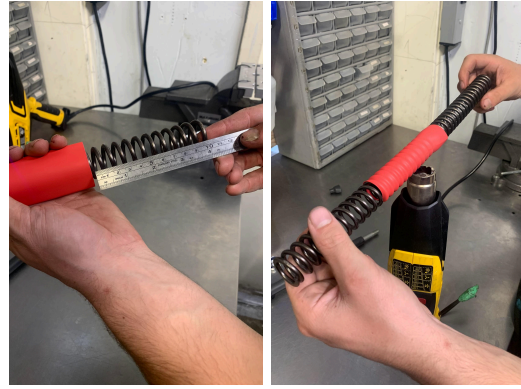

8. Install a stack height of MAIN SPRING SPACERS (and 2nd Spring if required) on the outer tube as required to suit your fork travel.

Note: 180 and 190mm settings both use secondary spring plus no spacer. The preload collar has sufficient adjustment range to permit this.

Main Spring Spacers	
Travel (mm)	Stack spacer height (mm)
140	0
150	10
160	20
170	40
180	0
190	0
200	10

9. **180mm, 190mm & 200mm TRAVEL UNITS ONLY:**

After installing any required MAIN SPRING SPACERS install the SECONDARY SPRING followed by a 2mm SECONDARY SPRING SPACER.



10. Install the MAIN SPRING on to the assembly followed by the SPRING COLLAR. Install such that the heat shrink sits closer to the spring collar in all but 35mm diameter stanchion forks where the orientation should be reversed.

Thread the collar on until there is 9mm of thread exposed on the STUD and stop.

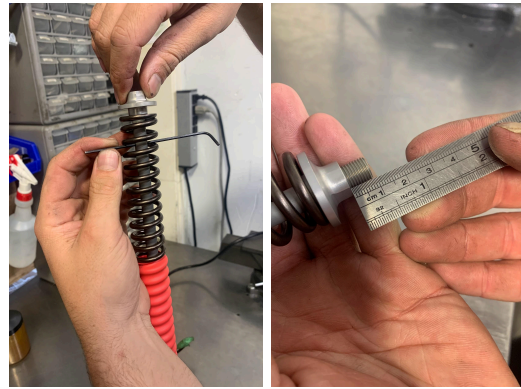

Update February 2026:

For Fox40 models only:

Use the spring collar delivered with your top cap kit, and install it instead of the spring collar that came with the inner tube kit.

Note orientation of the spring collar.



11. **If your Smashpot came with the grub screw type collar:**

Remove the set screw on the PRELOAD COLLAR and apply some blue 243 Loctite on it. Reinstall it in the collar, but ensure the collar is free to rotate around the outer tube.

Hold the smashpot unit upside down and rotate the PRELOAD COLLAR clockwise or anticlockwise, as required, such that there is no play in the system. E.g. spring cannot shift up and down but has minimal preload.



12. **GENTLY** snug the set screw against the flats on either side of the outer tube. **DO NOT OVERTIGHTEN OR DAMAGE WILL OCCUR.**

If you are blocking the holes, consider adding ½ turn or a full turn to make sure the nylon tip of the set screw does not protrude in one of those openings.

Double check that the **SPRING COLLAR** hasn't moved and there is still **9mm of thread** exposed.

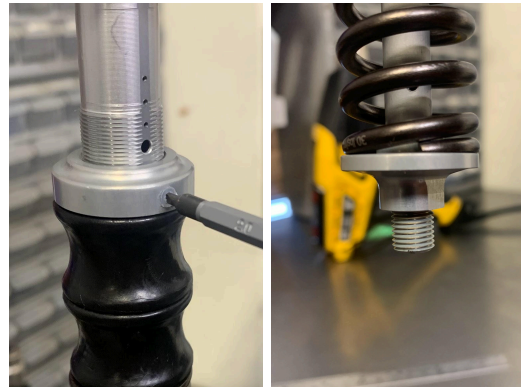

If your outer tube assembly came with two locking hex shaped preload collars:

Tighten one of the collars to eliminate the free play on the spring assembly and **gently snug** the second collar against the first one. Note the orientation of the collars in relation to the spring/spacers. The circular surface must face the spring to properly support the spring.



Tighten the two collars against each other to lock them into place. You will need a 24mm cone wrench for one of them. Torque spec: 11.3 Nm or 100in/lbs



13. DUAL CROWN FORKS ONLY:

Thread the TOPCAP on to the STUD on the DUAL CROWN TOPCAP EXTENDER and proceed with the steps as follows

Note there is no need to torque these parts together as torque will be transmitted through the whole assembly in the next step.



14. SINGLE CROWN FORKS ONLY:

If your fork topcap kit includes a 20mm extender, thread it into the topcap. Do not torque against the topcap – it will be torqued between the topcap and the inner tube/spring collar in the next step.

EXCEPTIONS – the following forks do NOT use the topcap extender included in the kit:

Fox 36 (all types) from MY2020 and earlier

Fox 36 Rhythm/Marzocchi Z1 (all years)

Fox 36 e-bike specific forks (caution: some forks are marked as “e-bike specific” that are actually standard 36 Factory/Performance forks)



15. Slide a 2mm allen key through the hole in the INNER TUBE and thread your TOPCAP to the assembly hand tight. This ensures the INNER TUBE doesn't spin as you install the TOPCAP and change the length of the exposed threads.



16. FOR SINGLE CROWN FORKS:

Remove the allen key and torque the TOPCAP against the SPRING COLLAR to 45 in.lbs (5.1Nm) using the chamferless socket and a 12mm wrench.

FOR DUAL CROWN FORKS:

Torque TOPCAP against SPRING COLLAR to 75in.lbs (8.5Nm)



The Smashpot assembly is now ready to be inserted into your fork and should look as pictured.

Single crown, shown with spring isolators already installed (note: 35mm single crown forks will have no heat shrink on the spring):



Dual crown, (shown **without** spring isolators* already installed) and with heat shrink closer to top of spring as used in forks with 36mm and higher stanchion diameters – Boxxer 35mm will have the heat shrink closer to the other end of the spring:



* For illustration purposes only, install spring isolators with every dual crown kit.

PART 3 – INSTALLING THE SMASHPOT ASSEMBLY INTO YOUR FORK

1. Remove the FOOTNUT and any crush washers from the footstud of the SMASHPOT unit.

Only the footstud should be left behind.

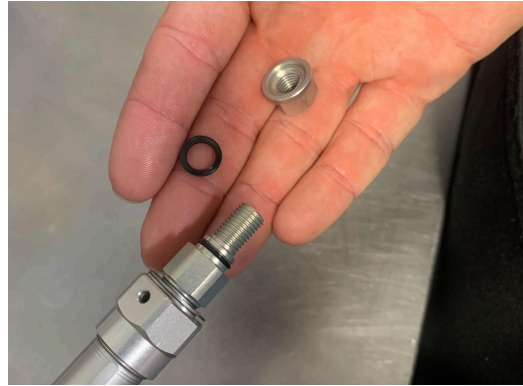

2. Apply a generous amount of Slick Honey grease to the COIL SPRING, especially the portion covered in Heat Shrink.



3. Install the SPRING ISOLATOR, it clips between the SPRING and the SPRING COLLAR in two pieces. Pull down on the spring to preload it and slide the SPRING ISOLATORS into place.

Lightly grease the outside of the isolators after installing.



4. Insert assembly into the fork as shown, squeezing the bottom of the SPRING ISOLATOR together to fit it through the top of the stanchion.

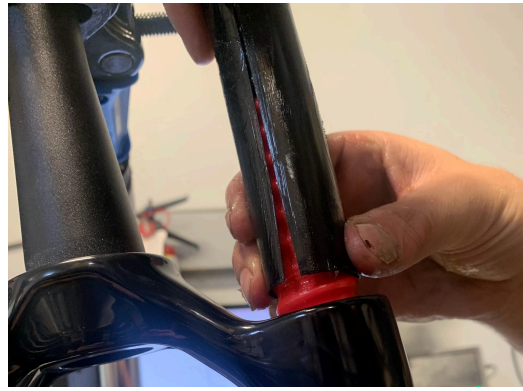

5. Use a Torque wrench and chamferless socket to torque the TOPCAP (without loctite) to:
- 220 in.lbs (24.8Nm) for FOX, MANITOU, EXT
 - 250 in.lbs (28.2Nm) for ROCKSHOX, OHLINS
 - 280 in.lbs (31.6Nm) for DVO



6. Using a syringe or graduated cylinder add oil to the lower leg.

Volume: 80ml (Except Fox 40 – 90ml)

Oil Specification: use a 5wt oil such as Fox 5wt PTFE, WPL ShockBoost 5wt, MOTOREX Racing Fork Oil 5wt, Maxima Plush 5wt

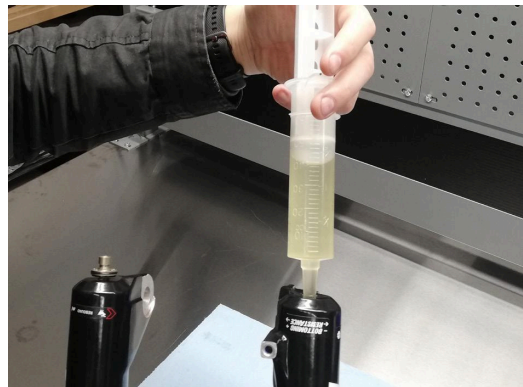

7. **FOX/ROCKSHOX FORKS ONLY:**
Install CRUSH WASHER and FOOTNUT onto the FOOTSTUD.



8. Use a Torque wrench and 12mm socket to torque the FOOTNUT to 55in.lbs (6.2Nm) without loctite. **DO NOT OVERTIGHTEN.**

NOTE: If the torque is not being applied and the footstud is spinning, compress the forks slightly while doing so to engage the press fit between the lowers and the SMASHPOT.

Apply Smashpot decals at your own discretion.



1. **DVO FORKS ONLY:**

Install 203 O-ring, WASHER and FOOTNUT onto the FOOTSTUD.

(Smashpot V1 footstud pictured)

Use a Torque wrench and 12mm socket to torque the FOOTNUT to 55in.lbs (6.2Nm) without loctite. **DO NOT OVERTIGHTEN.**

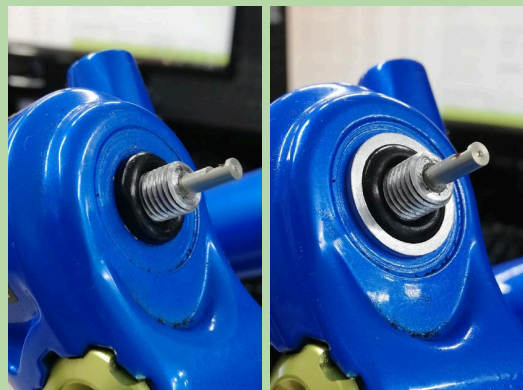

2. Use a Torque wrench and 12mm socket to torque the FOOTNUT to 55in.lbs (6.2Nm) without loctite.

Apply Smashpot decals at your own discretion.



1. **OHLINS FORKS ONLY:**

Use a Torque wrench and 14mm socket to torque the FOOTNUT to 90in.lbs (10Nm) without loctite. **DO NOT OVERTIGHTEN.**

Apply Smashpot decals at your own discretion.

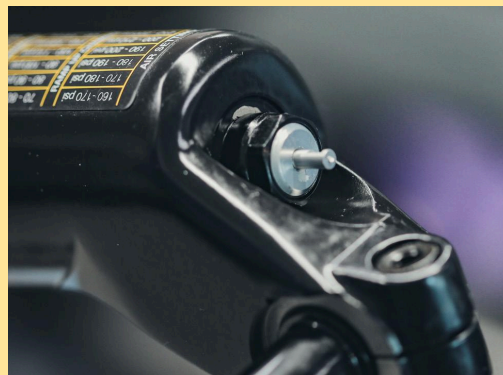

Installation is complete. Now go ride your bike!

SMASHPOT TUNING – HBO ADJUSTMENT

The Smashpot utilizes a hydraulic damping system that engages during the last third of the fork travel in order to prevent harsh bottom out of the suspension. The amount of damping force can be adjusted by modifying the adjuster dial position or by modifying the shim stack. Given you are running the correct spring rate for your weight and riding style, the adjustment range provided by using the adjuster dial should be adequate for the majority of riders.

To adjust the bottom out stroke compression damping requires a **2mm** hex key.

The adjuster shock has a minimum of **16 clicks** of adjustment (additional clicks are not an issue) and the settings should be counted as clicks out from fully closed.

DO NOT FORCE THE ADJUSTER PAST ITS STOPS!

To **increase (+)** bottom out stroke compression damping (firmer), turn the adjuster needle clockwise.

To **decrease (-)** bottom out stroke compression damping (softer), turn the adjuster needle anti-clockwise.

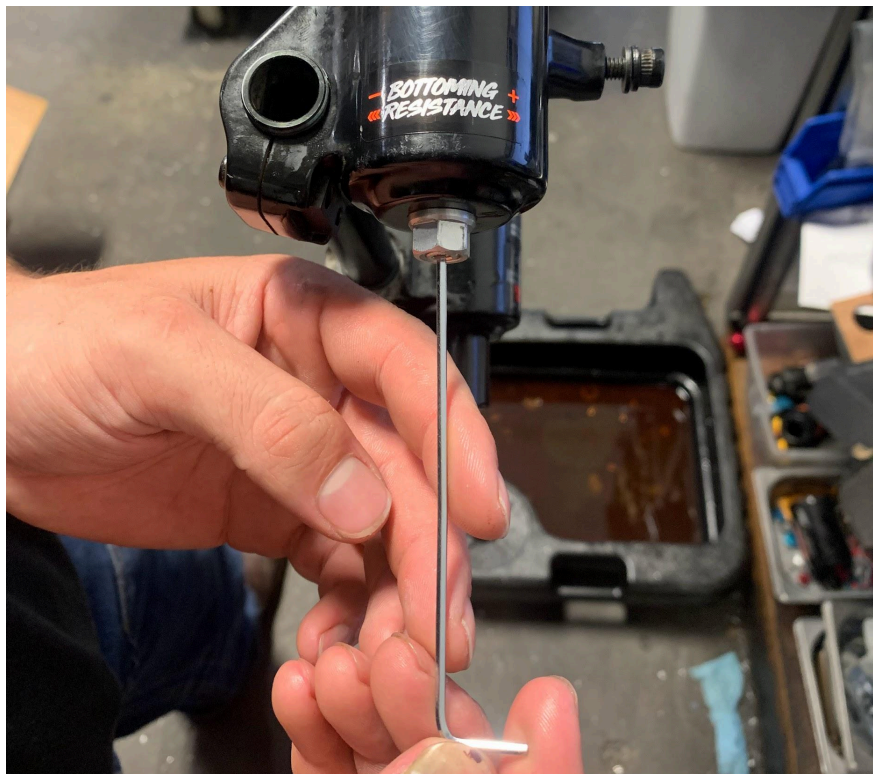

SERVICING YOUR FORK LOWERS & SMASHPOT

1. DAMPER SIDE:

Refer to the Factory service instructions for removal of the Rebound Adjuster Knob, Bottom Nut & Crush Washer

2. SPRING SIDE:

Use an appropriately sized socket, remove the FOOTNUT and any CRUSH WASHERS/O-RINGS.



3. Use a chamferless socket to undo the TOPCAP.



4. Reinstall just the FOOTNUT onto the FOOTSTUD hand tight & unwind approximately 4 turns. Place a socket over the FOOTNUT. Strike the socket to dislodge the unit from the lower leg. The bolt head should contact the bottom of the lower leg.

5. Also dislodge the DAMPER SIDE as per Factory service instructions.

Proceed with service as per Factory service instructions.

SERVICING YOUR SMASHPOT

1. Remove Smashpot assembly from your fork. (See 'SERVICING YOUR FORK LOWERS & SMASHPOT' for more details.)
2. The Smashpot requires minimal servicing.
Check the placement of the heat shrink as it can move over time.
Check the preload is correct.
Inspect and thoroughly clean the unit, re-grease and re-install as per PART 3 of this Installation Manual.

CHANGING COIL SPRINGS

If you wish to remove and replace the spring, this can be done by following the below procedure. Note: having a new, clean gear shift cable on hand will make this a much easier process

1. Use a chamferless socket to undo the TOPCAP.



2. Use the same chamferless socket on the and a 12mm Spanner on the SPRING COLLAR to remove the TOPCAP.



3. Remove SPRING COLLAR, SPRING ISOLATOR and COIL SPRING.
The INNER TUBE will fall down inside the stanchion. Compress the fork fully and you should be able to grab the INNER TUBE and pull it out of the stanchion.



4. Thread a gear shift cable through the hole in the top of the INNER TUBE and through the new COIL SPRING. The COIL SPRING should be orientated with the HEAT SHRINK closest to the top.



5. Use the shifter cable to pull the INNER TUBE up through the COIL SPRING until the threads of the INNER TUBE are exposed above the COIL SPRING.



6. Install the SPRING ISOLATOR and SPRING COLLAR onto the INNER TUBE and tighten down until 8–10mm of threads are exposed.



7. Thread the TOPCAP onto the INNER SHAFT ASSEMBLY.

Using a Torque wrench + chamferless socket on the TOPCAP and a 12mm Spanner on the SPRING COLLAR, torque to:

SINGLECROWN FORKS: 45in.lbs (5.1Nm)

DUAL CROWN FORSK: 75in.lbs (8.5Nm)

DO NOT EXCEED TORQUE SPECIFICATION.

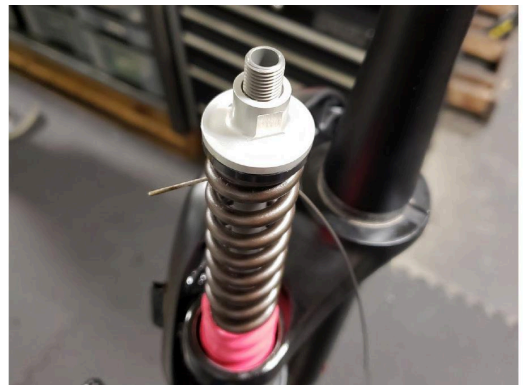

****It is important that the SPRING COLLAR be tightened against the TOPCAP. Do not simply tighten the TOPCAP onto the INNER SHAFT until the threads bottom out. This will damage the assembly**



8. Torque the TOPCAP (without loctite) to:
- 220 in.lbs (24.8Nm) for FOX
 - 250 in.lbs (28.2Nm) for ROCKSHOX
 - 280 in.lbs (31.6Nm) for DVO
 - 250 in.lbs (28.2Nm) for OHLINS



CHANGING FOOTSTUDS

The Smashpot is a modular unit meaning it can be configured to fit in any compatible fork. To move your Smashpot between forks requires that you replace one or both of the TOPCAP and FOOTSTUD.

Footstud changes are required to move the smashpot between brands e.g. Fox to Rockshox

Top-cap changes are required to move between any fork model.

1. Remove Smashpot assembly from your fork. (See 'SERVICING YOUR FORK LOWERS & SMASHPOT' for more details).

2. Using a 2mm Hex turn the HBO NEEDLE to the fully closed position (all the way clockwise)



3. Using a 19mm Wrench to hold the BASE VALVE, Unthread the FOOTSTUD a quarter turn with an appropriately sized socket (size varies by footstud type).



4. Using a 2mm hex key to keep the HBO NEEDLE from spinning, unthread the FOOTSTUD from the unit. Take care not to remove any shims which may stick to the FOOTSTUD when removing it. Shim Stack configuration as follows:
 - 5x 9.0x18.0x0.1mm (Face shims - against base valve), - 2x 9.0x16.0x0.2mm, - 2 x 9.0x 11.0x0.2mm (Clamp shims - against footstud)



5. Hand tighten the new FOOTSTUD into place making sure not to pinch any of the shims when doing so.



6. Using a 19mm wrench and an appropriately sized socket, torque the FOOTSTUD to 75 in.lbs (8.5N.m) without loctite.



Questions?

support@vorsprungssuspension.com

www.vorsprungssuspension.com